



LEE FILTERS



THE SYSTEM



INSPIRING PROFESSIONALS

Lee Filters Andover England

Tel: +44 (0)1264 338599 Fax: +44 (0)1264 355058 Web: leefilters.com Email: sales@leefilters.com



INSPIRING PROFESSIONALS

contents

three	<i>the LEE system and your camera</i>
six	<i>lens adaptors</i>
eight	<i>filter holder</i> <i>filter holder versatility</i> <i>filter holder - the range</i>
fourteen	<i>lens hoods</i> <i>lens hoods - the range</i>
seventeen	<i>the photographic filter choice</i> <i>resin filters</i> <i>technical filters</i>
fifty seven	<i>accessories</i>
fifty nine	<i>darkroom products</i>
sixty one	<i>lighting products</i>
sixty four	<i>index</i>



an introduction to LEE Filters

As a company, Lee Filters is renowned for the high quality and technical excellence of its product range.

Lee Filters have developed filters and equipment for the stills photographic market by applying the same principles that have brought them years of success in the demanding film, television and theatre industries.

The principles they apply are clearly defined - all products are manufactured to the most stringent standards of quality, the approach to product development is both practical and innovative, and all aspects of design, including packaging, are undertaken with the needs of the photographer in mind.

A prime example of a product that was developed with a view to innovation and practicality is the highly versatile filter holder system. This system has a number of unique features that offer the photographer the highest levels of technical and creative flexibility.

The Lee Filters range consists of lighting filters and front-of-lens products, such as holders and photographic filters and darkroom products including colour printing filters and viewers.

The lighting filter range includes colour effect and diffusion grades, most of which are manufactured at the company's plant in Andover, Hampshire.

Lee Filters' entire system has been designed with the photographer in mind so read on to discover how it will benefit you and your photography.

the LEE system and your camera

The Lee Filter holder system is so versatile that it can be fitted to almost any lens on any camera. This means that whether the photographer is using a 35mm, medium, large format or even extreme wide-angle lens, they will always enjoy the performance and benefits the system provides.

An adaptor ring that screws onto the front of the lens is the key to the versatility of this system. Once the appropriately sized adaptor is fitted, the rest of the system clips neatly and easily into place.

Total flexibility has been designed into the Lee Filter holder system.



The LEE System and your camera

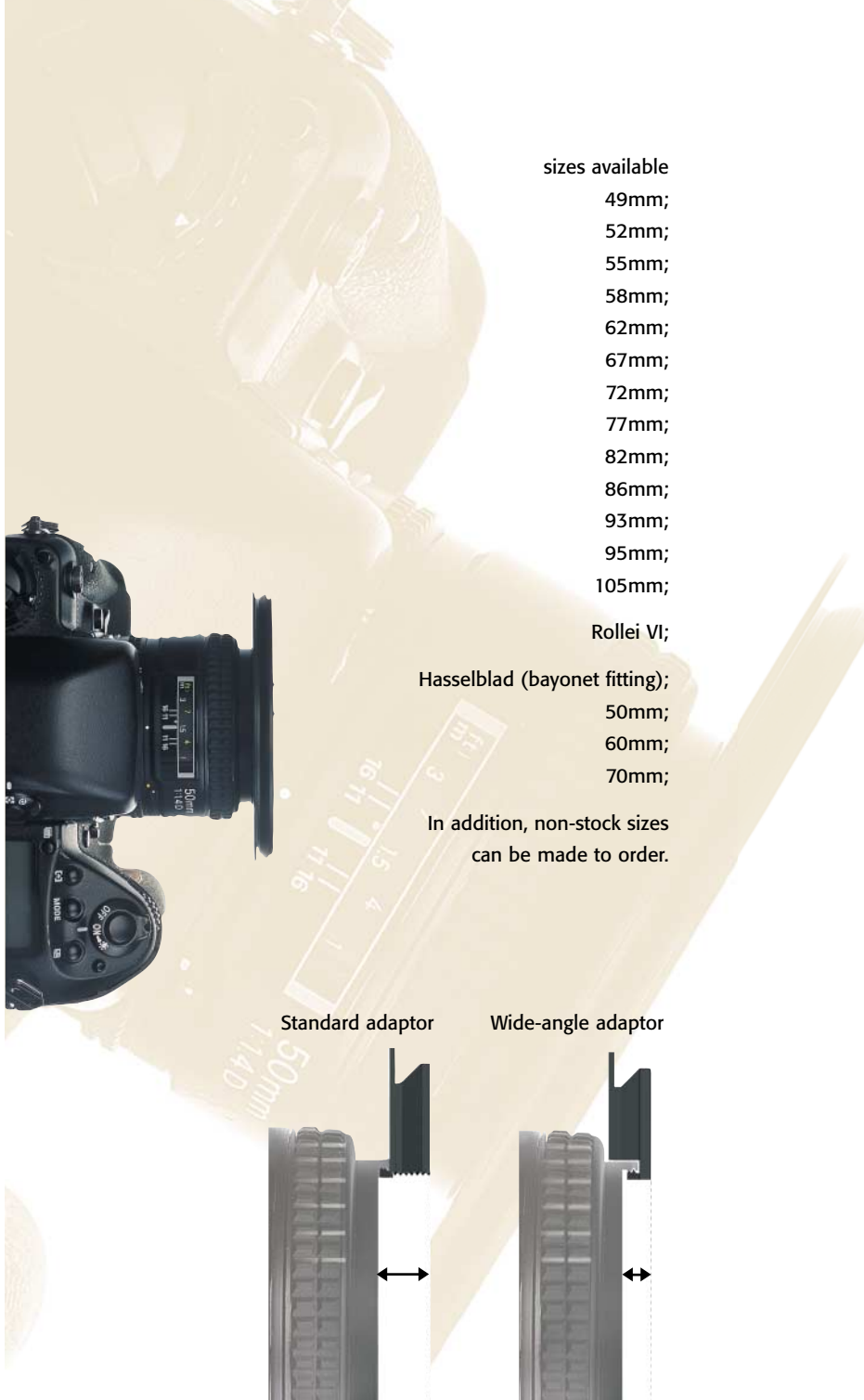

sizes available

- 49mm;
- 52mm;
- 55mm;
- 58mm;
- 62mm;
- 67mm;
- 72mm;
- 77mm;
- 82mm;
- 86mm;
- 93mm;
- 95mm;
- 105mm;

Rollei V;

Hasselblad (bayonet fitting);

- 50mm;
- 60mm;
- 70mm;

In addition, non-stock sizes can be made to order.

Standard adaptor

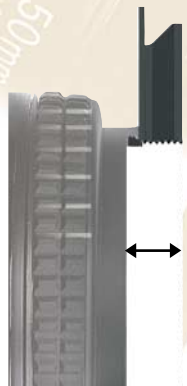

Wide-angle adaptor



lens adaptors

Adaptor rings fit into the lens to accommodate the filter holder. Once the adaptor is in place the filter holder clips firmly to it using a smooth, quick-release, spring-loaded mechanism.

Sturdily constructed with an aluminium screw thread, the adaptors are available in both standard and wide-angle configurations. Special sizes can be made to order.



The wide-angle adaptors are designed so that the filter is placed as close as possible to the front element of the camera lens, and should be used when vignetting is encountered with a standard adaptor ring.

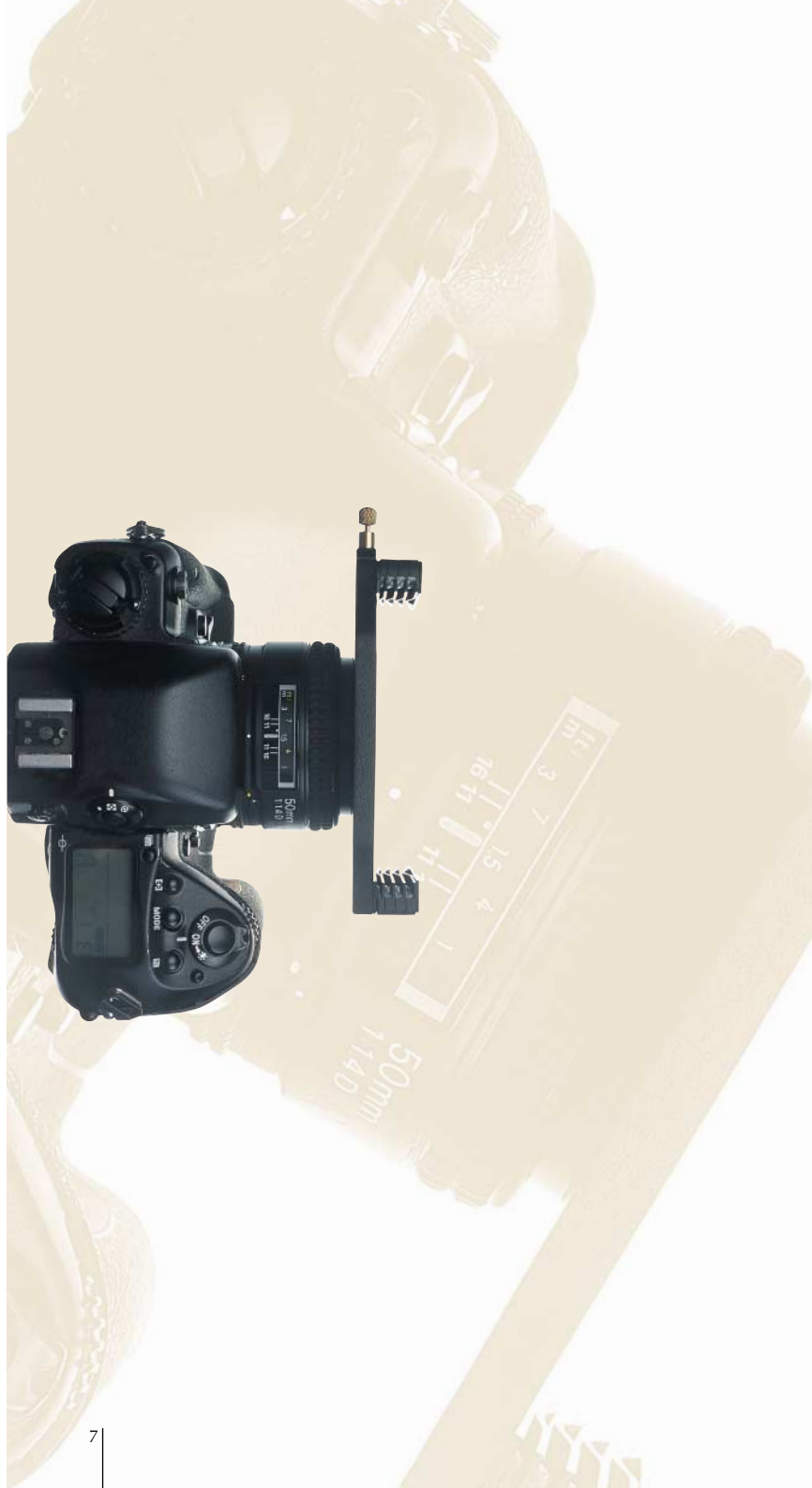

filter holder

The foundation kit is at the centre of the Lee Filter holder system and is primarily designed to take standard 100mm filters, although other filter sizes can be adapted to fit. The unit is supplied in component form to allow the photographer to construct a filter holder tailored to his or her individual needs.



Once constructed, the holder clips easily onto the adaptor ring and can then be rotated to position filters to the photographer's exact requirements. This also enables optimum use of graduated and special effects filters.

This kit contains all the components necessary to construct a versatile holder, capable of holding up to four filters. The photographer can then choose which combinations of filter thicknesses they want to use by selecting and fitting the appropriate filter guides with the screwdriver provided. Additional guides and screws can be purchased separately.

filter versatility

The diagram below shows the assembly of a foundation kit. A pair of back cover plates is fitted onto either side of the back plate. Next, the filter holder guides are also fitted onto either side of the back plates. Up to four guides can be fitted, depending on the number of filters the photographer wishes to use, (extra guides can be added for additional filters). If the photographer wishes to rotate further filters independently of the filters already held by the filter holder, they will require an upgrade or professional kit.

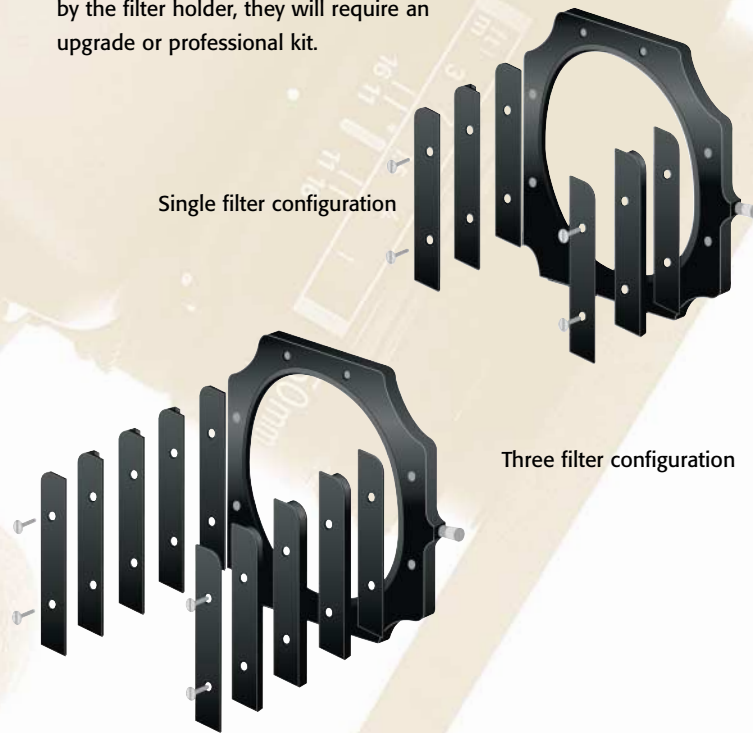

Single filter configuration

Three filter configuration

When the photographer is assembling the filter holder, account must be taken as to their requirements. The more filter guides the narrower the angle of view. For use on extreme wide-angle lenses, only one or maybe two guides are recommended.



Attaching the 105mm accessory ring instead of the front cover plates will allow a polariser to be attached. This enables a polariser and a graduated filter to be used together in conjunction with a wide-angle lens.



foundation kit



The foundation kit is the basic filter holder package, and clips easily onto the adaptor ring. It allows 1,2,3 or 4 filters to be attached to almost every lens on every format of camera.

upgrade kit



For photographers who already own a foundation kit, the upgrade package takes the holder system to professional kit standard. The pack contains all the components needed to create a single filter holder with up to four sets of slots, together with a tandem adaptor that enables the holder to slot easily onto the front of the foundation kit allowing independent rotation.

professional kit



The professional kit contains two basic filter holders that connect together via a tandem adaptor, allowing even more filters to be fitted in front of the lens. Each holder can then be individually turned to achieve independent rotation of grads and polarisers.

push on filter holder

The perfect solution for ultra wide-angle, large and medium format photography, the push on filter holder is designed to fit directly onto lenses, and has an outside barrel diameter of 100mm. The holder attaches directly onto the lens itself and such close proximity allows the maximum possible angle of view without vignetting. Custom adaptor donuts are available to enable fixing to smaller lenses. The unit also has the added advantage of using standard 100mm filters.



specialist filter holders

Also available is the option of custom-made filter holders, allowing the photographer to fit filters to cameras and lenses that would otherwise not be compatible with a filter system. These holders are customised to each individual's requirement.



lens hoods

Lee Filters were the originators of the self-supporting lens shade, a technology which is now used throughout our range of hoods. The bellows are manually adjusted to the required position without using rails or guides and thereby reducing size and weight. They are completely flexible and can be used off-angle to selectively shield or match movements on a large format camera.



The Lee Filters range of lens hoods is available in many configurations to suit all types of camera equipment and all types of photography. They can be attached to the Lee holder or direct to the adaptor ring.



standard hood

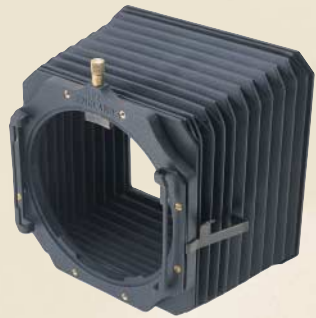

The standard hood fits any Lee Filters holder configuration, provided a 2mm slot is fitted to the front of the holder, or can be fitted directly to the lens adaptor ring. The self-supporting bellows adjust to the required position without using guides or rails. Additionally, a set of guides to enable vignettes to be fitted is available and can be placed in front of the hood for added versatility.

slotted filter hood and double slotted filter hood

slotted filter hood



The slotted filter hood has all the features of the standard hood except that it is designed only to fit directly to the lens via an adaptor ring. It features either one or two 2mm (double-slotted filter hood) filter slots immediately behind the bellows with vignette guides already fitted. This unit is ideal for social or studio photographers who may not require a full filter holder.

double-slotted filter hood

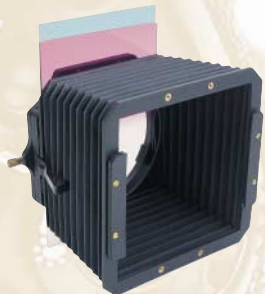

universal hood

As its name suggests, the Universal hood can be configured by the photographer to suit many specific needs. It can be a simple lens shade, or have room for one, two or three filters in any standard thickness. Its size and shape make it an ideal general-purpose hood, and for shading wide-angle lenses on 35mm and medium format cameras.



wide-angle lens hood and slotted wide-angle lens hood

Lee Filters wide-angle lens hoods have much larger bellows to allow for effective shading on wide or particularly large lenses, where the use of standard hoods could cause vignetting.

The unit is available as a wide equivalent of either the standard hood or the slotted hood.



wide-angle lens hood

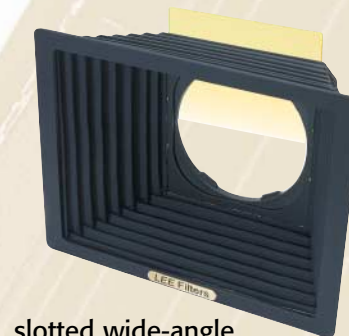

slotted wide-angle lens hood



Standard hood closed

Standard hood open

Wide-angle hood closed

Wide-angle hood open

the photographic filter choice



resin filters

The Lee Filters resin filter range includes colour effect, graduated, striped and special effect filters, available in either economically packaged boxed sets or as single items. Standard sizes to fit the Lee Filters system are 100 x 150mm or 100 x 100mm. Sizes to fit other filter holder systems are also available on a customised basis.

The resin filters are made from lightweight, optically correct polymeric materials, which makes them tough, easy to handle and they can be wiped clean. Every filter is individually hand made by skilled technicians and is then passed through a rigorous quality control system to ensure 100% accuracy and consistency.

Graduated filters feature an area of colour at one end of the resin, with the opposite end remaining clear. This enables the colour or effect to be placed in a specific area of the frame by the positioning of the filter either up or down in the holder. The transition from colour to clear can be either fast (hard grad) or slow (soft grad).

Stripe filters are used to place a band of colour or effect across a specific area of the frame.

The special effects range features a wide selection of fogs, nets, starbursts, low contrast and soft focus filters.

polyester filters

The Lee Filters technical filter range has been designed to overcome the problems that are created by the interaction of different light sources with modern film. The filters are manufactured from the highest quality polyester-based material, as polyester is tough, impervious to water and easy to clean. These filters can be mounted in frames or cut to fit the photographers existing filter system. All the filter sets are supplied ready mounted for use with the Lee holder system.

In addition to standard correction filters, the range of technical filters include fluorescents, correction and neutral densities, together with colour-compensating and colour printing grades.

glass filters

Lee Filters also offers a range of photographic filters in glass, including star filters, polarising filters and an enhancing filter to accentuate reds and oranges without affecting other colours.

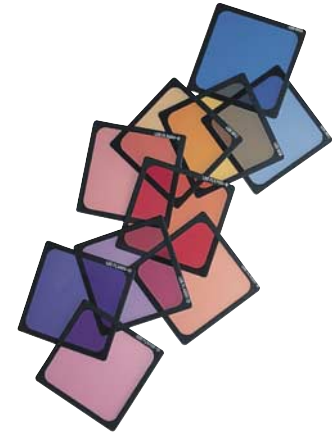

service

Service is at the heart of the Lee Filters' philosophy, and the company employs more than 100 people whose prime concern is to manufacture high quality products for customers worldwide.



neutral density

graduated filters



0.3 neutral density

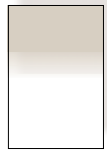

0.45 neutral density

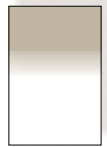

0.6 neutral density

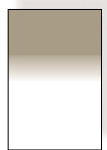

0.75 neutral density



0.9 neutral density

unfiltered



filtered



filters used

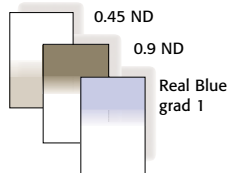

The Lee Filters range of true, neutral density (ND) graduated filters enables the photographer to selectively adjust exposure across the frame without affecting the colour balance. They are available in half-stop increments from 1 to 3 stops and with a choice of hard or soft graduation.

These filters can be used singularly or in combination to provide a variety of effects - the only limit is the extent of the photographer's imagination!

The most common use for a single ND grad would be to balance the exposure difference between the sky and the foreground, retaining the natural colours and detail without over-exposing and "burning out" parts of the image.

In the example right, the brightness of the sky has been reduced by 2 stops, using a 0.6 neutral density grad. The foreground exposure remains unaffected.

unfiltered



filtered

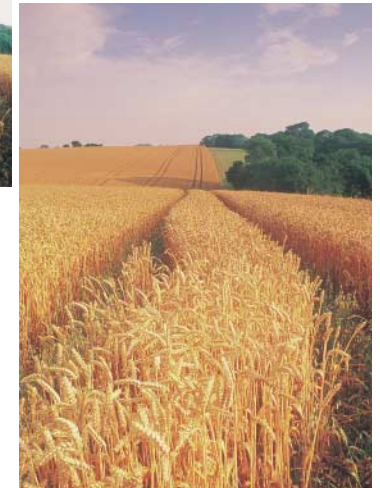

filter used

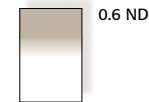

ND filters can also be used to lengthen exposure times and cause any moving part of the image to blur. This is effective for seascapes, rivers and waterfalls, as well as adding a dynamic quality to crop fields, long grass and crowds of people.

In the example right, a 0.6 ND grad has been inverted to reduce the foreground exposure by 2 stops (a longer shutter speed allows the moving water to blur). A 0.75 ND at the top of the image darkens the sky by a further 1/2 stop to provide balance.

ND filters are truly the essential filter for the landscape photographer.

unfiltered



filtered



filters used

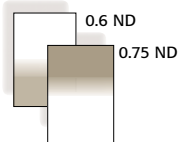

effects filters



section contents

- twenty two *neutral density set*
- twenty three *sky set*
- twenty four *autumn tint set*
- twenty five *sunset set*
- twenty six *twilight set*
- twenty seven *sunrise set*
- twenty eight *landscape set*
- twenty nine *colour grad set*
- thirty *sky blue set*
- thirty one *coral set*
- thirty two *pale tint set*
- thirty three *pop set*
- thirty four *stripe set*
- thirty five *mist set*
- thirty six *selective star set*
- thirty seven *glass soft focus filter*
- thirty eight *soft focus soft set*
- thirty nine *net set*
- forty one *single filters*
- forty five *polarising filters*
- forty seven *enhancer*

The following pages contain details of the Effects Filters that Lee Filters has on offer. Many are available in sets, each of which is packaged in a sturdy "push-up" box, making for simple selection and handling. Designed for everyday use, the box is tough enough to protect the filters in transit in the photographer's bag or an equipment case.

The variety of sets means the photographer has a wide choice of effects, suitable for any location. Filters from any of the sets can be combined to achieve various effects.

Standard sizes for the system are: 100 x 150mm for graduated filters and 100 x 100mm for standard filters.

neutral density set

The Neutral Density set can be used with all standard film types and contains graduated resin filters enabling the photographer to adjust exposure over part of the photograph without affecting the colour balance. Exposure can be controlled by 1, 2 or 3 stops, to suit the individual situation.

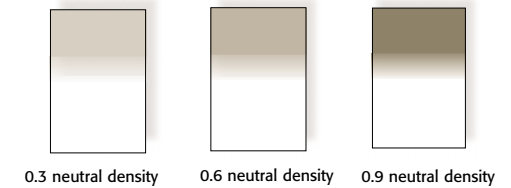

For example, when photographing a landscape in which the sky is much brighter than the foreground, placing the neutral density part of the filter onto the sky in the frame will reduce the sky exposure without affecting the foreground.

This enables cloud detail to be kept correctly exposed in the picture, and avoids the "white out" effect caused by exposing for the foreground.

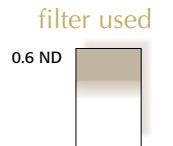

A 0.6 ND graduated filter reduces the brightness of the sky by 2 stops, foreground exposure is unaffected.

unfiltered



filtered



sky set

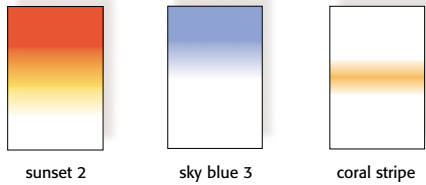

This set contains Sunset 2, Coral Stripe and Sky Blue 3 graduated filters, which may be used individually or in combinations to enhance sky tones in landscapes, seascapes and general outdoor photography. The Coral Stripe is ideal for creating a warm glow on the horizon, and can be placed strategically in the frame, creating an effect across a particular object or section of the image. The sunset filter can be used to create or enhance morning and evening skies.

filter used

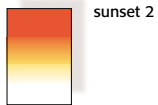

The sunset filter can be moved up or down in the holder to provide a variable graded colour change from red to yellow.

filtered



autumn tint set

This set which consists of Tobacco 2, Coral 6 and Chocolate 2 filters, can be used to create atmospheric autumnal effects. These filters have been designed both as hard graduates and standard filters - a feature that has been achieved by manufacturing the filter with the graduation line 90mm from the top of the filter. This gives ample room for the photographer to place the coloured portion of the filter either over the whole lens, as a standard, or only half-way over the lens, as a grad.

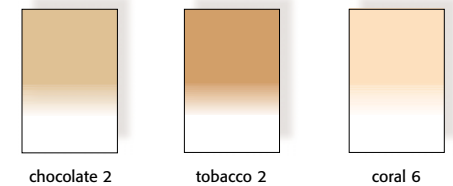

filters used

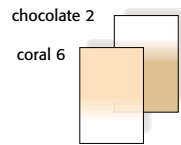

unfiltered

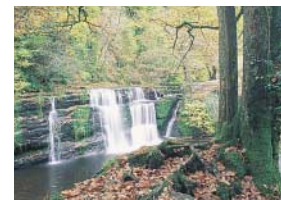

The Coral 6 has been used to enhance and give a depth of colour to the foliage in the background. The chocolate is inverted to colour the foreground leaves.

filtered



sunset set

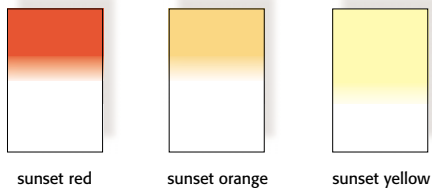

The popular three-colour sunset filter is now available as a set of three separate filters - Sunset Red Grad, Sunset Orange Grad and Sunset Yellow Grad. This offers the photographer the flexibility and control they need to achieve the result they want, adding warmth and definition to both sky and landscape.

filters used

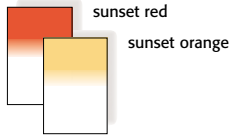

Using the red and orange filters together, staggered and at an angle, a graduation from red to orange has been achieved across the frame.

filtered



unfiltered



twilight set

For a more subtle effect the twilight set contains a paler, thinner version of Lee Filters Coral Stripe filter. It is teamed with a Mahogany 3 Grad, which gives an ideal "red sky at night" effect, and a dark blue Twilight filter for capturing the moment when day finally turns to night.

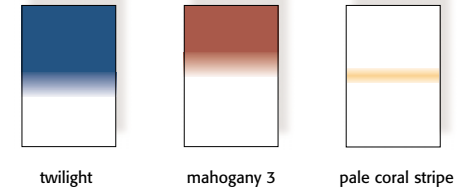

filter used

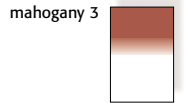

A mahogany 3 grad placed over the top half of the image only, darkens and adds colour to the sky. The exposure should be calculated without the filter and remain unchanged once the filter is in place.

filtered



sunrise

set

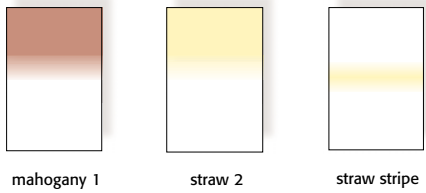

A set of three bright, warm colours for dawn or sunrise photography. The Straw 2 Grad filter is a fairly strong yellow and is a good warm-up filter. Mahogany 1 Grad helps achieve a paler sunrise effect, while placing the Straw Stripe across the horizon adds warmth.

filter used

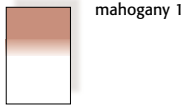

A mahogany 1 grad adds subtle colour and reduces the brightness of the sky with no effect on foreground detail.

filtered



unfiltered



landscape

set

Designed to compliment the landscape, whether rural, suburban or busy city centre. The set contains Real Blue 2 Grad which gives a deeper hue to blue or grey skies, a Straw 3 Grad, which when inverted adds warmth to the foreground, and a Sepia 2 Grad, a deep chocolate colour which enhances rocks, foliage and fallen leaves.

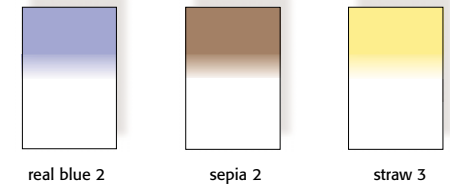

filters used

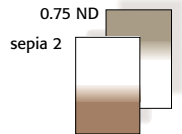

A 0.75 ND Grad (2^{1/2} stops) balances the exposure of the sky, keeping the natural colour and detail, while the sepia 2 is inverted to colour the foreground rocks only.

unfiltered



filtered



colour grad set

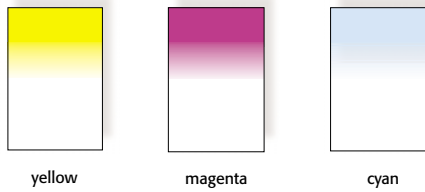

This is a set of three graduated filters - Cyan, Yellow and Magenta - used to create special effects and to colour a chosen section of the image being photographed. By using these filters in varying combinations, red, blue and green effects can also be created. Additionally, effects can be achieved by using the filters in opposition to each other. The cyan, for example, could be on the top of the frame, enhancing the sky, whilst the yellow could be adding colour to faded grass.

filter used

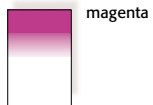

A magenta grad adds some colour to an otherwise bland skyline. The meter reading should be taken from the foreground and remain unchanged when the filter is in place.

filtered



unfiltered



sky blue set

The Sky Blue Set contains Sky Blue 1, 2, and 3 graduated effect filters from the sky blue series, allowing addition of varying degrees of colour to otherwise grey or colourless skies. These filters are ideally suited for use in land and seascapes.

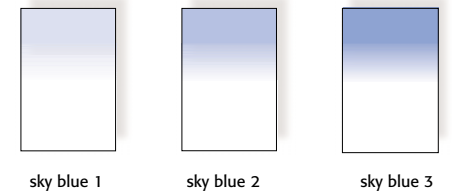

filter used

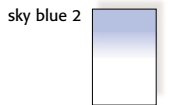

A sky blue 2 grad adds a tint of blue to a sky that cannot be enhanced by a neutral density or polariser.

filtered

unfiltered



coral

set

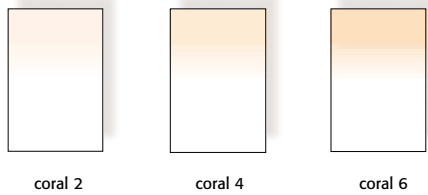

These three pale to mid-tone, coral grads (2, 4 and 6) can be used as general warm-up filters, or provide special effects. They can also be used to create slightly orange skies. These filters come from the coral range of products, where, as the number in the series increases, the amount of colour temperature correction increases.

filters used

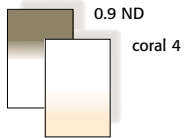

A 0.9ND Grad is used to correct the exposure difference between sky and foreground whilst an inverted coral grad enhances the effect of the low sun on the foreground ferns.

filtered



unfiltered



pale tint

set

This set comprises the number one grade (palest) from the green, pink and cyan filter ranges. It offers the photographer an opportunity to create truly subtle tints in the chosen areas of the frame by positioning the colour through rotation of the filter holder, and by moving the filter up or down.

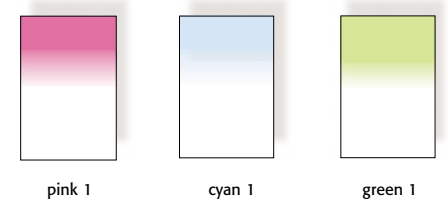

filter used

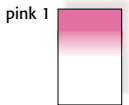

A pink 1 grad adds some colour to an otherwise bland skyline. The meter reading should be taken from the foreground and remain unchanged when the filter is in place.

filtered



unfiltered



pop set

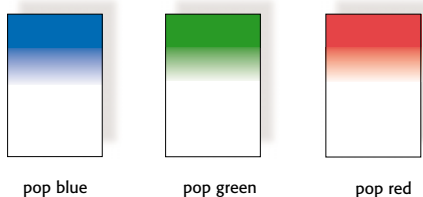

This set of graduated filters features three primary colours - red, green and blue - for selective colouring over parts of the frame. These filters are ideal for creating special effects, and can be accurately placed by using the rotational feature of the holder system, or by vertical positioning within the filter guides.

filters used

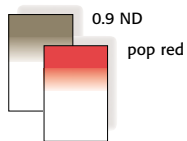

filtered



A 0.9 neutral density grad, covering virtually the whole frame increases the exposure by 3 stops, allowing the water to blur. The pop red adds a dramatic tint to the clouds.

unfiltered



stripe set

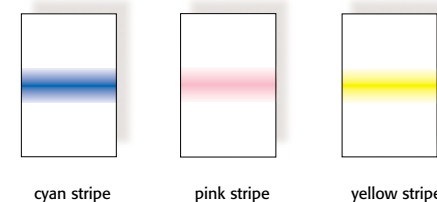

The stripe set comprises a set of three filters - yellow, pink and cyan - each with a stripe of colour placed horizontally across the centre of the filter. This enables the colour to be positioned anywhere in the frame, either by rotating the filter holder or by sliding the filter up or down in the holder guides. This set is ideal for creating special effects. The stripe - due to its position on the actual filter - allows itself to be positioned from the lowest point in the frame to the highest.

filters used

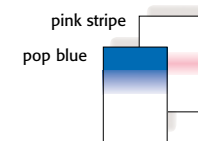

unfiltered



The pop blue at the top of the frame balances the dark area at the bottom, leading the eye to the horizon where the pink stripe gives a twilight feel.

filtered



mist

set

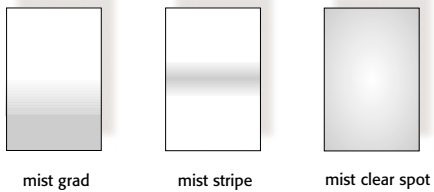

This set consists of a Graduated Mist, a Mist Stripe, and a Mist Clear Centre Spot. These filters can be used individually or in combinations to create varying densities of mist and fog. The stripe can often be used to cover the foreground of the shot, providing a feeling of depth of fog, while the clear centre allows the viewers eye to be taken straight to the all-important subject. The flexibility of positioning offered by the Lee Filter Holder System significantly increases the choice of effects available to the photographer.

filters used

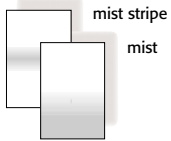

The mist grad has been inverted and used in combination with the stripe at the bottom of the frame to give a low lying mist effect.

filtered



unfiltered



selective star

set

This set is made up of a Star Spot filter (4pt), a Star Graduated filter (6pt) and a Star Segment filter (8pt). Using these filters, it is possible to create star effects on highlights in various parts of the frame. The Star Spot has a circular cluster of markings to create stars, while the Star Segment will place highlights in a chosen position of the shot. The Star Graduate makes highlights at one end of the filter, reducing to clear resin at the other. Careful inspection of the filters will allow the photographer to determine where the star effect will appear.

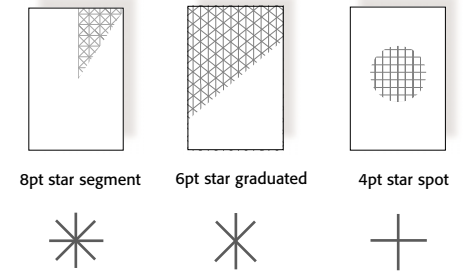

filters used

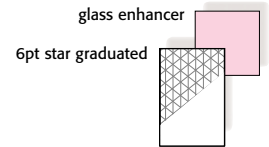

unfiltered



The star effect can be seen on left hand side of the image, the selective star grad ensures that all other highlights are unaffected. The enhancer was used to colour the stonework of the bridge.

filtered



glass soft focus filter

For the portrait, wedding or studio photographer, the Lee glass soft focus filter gives a gentle, flattering effect, which is not obviously noticeable unless you have an unfiltered shot alongside for comparison.

This new filter has minimal effect on the contrast, and does not overpower the image. Changes in aperture or focal length will not have an adverse effect.

And it is not just for indoor use. For the landscape photographer, using it to soften objects in the foreground can give a pleasing, almost 3D effect to the image.

A valuable addition to any photographer's kit, the Lee glass soft focus filter is available in 100 x 100 x 2mm format, to fit the Lee Filter system.

Unfiltered



Filtered



soft focus soft set

Based on filters originally developed by Lee Filters for use in the film industry, the Soft Set consists of five soft filters that take the image from a subtle, barely noticeable softening to a heavy diffusion.

Made from the highest quality, optically correct polyester-based materials, these lightweight and inexpensive filters are ideal for every type of portraiture and social photography. Mounted in plastic frames for extra protection, the filters slip easily into the photographer's filter holder system, to give the outstanding results expected from a Lee Filters product.

LEE Soft 5



LEE Soft 3



Unfiltered



Soft 1



Soft 2



Soft 3



Soft 4



Soft 5

net

set

Based on net filters commonly used in cinematography, these filters provide a subtle soft focus effect while also increasing (black net) or decreasing (white net) contrast. If required the selective hole can be slid into the frame to provide an unaffected clear centre effect.

The black net 1 has an approximate exposure increase of $\frac{1}{2}$ stop. Whilst the black net 2 has a approximate exposure increase of 1 stop.

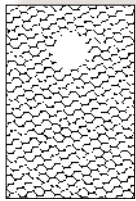

black net 1

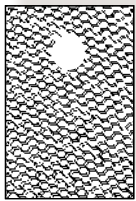

black net 2

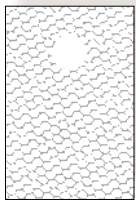

white net

black net 1

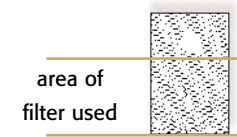

unfiltered

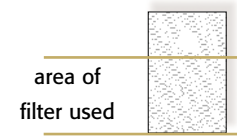

white net

single effects

filters

Red
For colour effects.
*Pop**

Sunset Red
The red portion of the sunset grad.
*Red**

Sunsets
Gives a sunset effect, which is ideal when shooting into a low sun.
1 2* 3

Yellow
For colour effects.
*Yellow** *Stripe**

Sunset Yellow
The Yellow portion of the sunset grad.
*Yellow**

Straw
A greater yellow warm-up for landscapes. Accentuates foregrounds when inverted.
1 2* 3* *Stripe**

Sunset Orange
The orange portion of the sunset grad.
*Orange**

Pale Coral
Paler and thinner than the coral stripe for a more subtle effect.
*Stripe**

Coral

Pinkish warm-up filter, redder than the 81 series.

1 2† 3 4* 5

6* 7 8 9 10

11 12 13 14 *Stripe**

Chocolate

Accentuates autumn leaves, stone etc.

1 2†

1 2† 3

Tobacco

Darker and redder than chocolate or sepia, a very strong effect.

Sepia

Gives a brown tinted monochrome look, less red than chocolate.

1 2 3

Green

For colour effects.

1* *Pop**

Blue

A deep reddish blue, mainly for colour effects.

*Pop** *Stripe**

* available as part of a set

† filter in the set is an extended graduated version

* available as part of a set

single effects

filters



Real Blue

Darker & blacker than Sky blue, gives a deeper effect to skies.

Sky Blue

A greenish blue to add realistic colour to flat skies.

Cyan

For colour effects.

Twilight

Deep blue/black gives a monochromatic twilight look.

Mahogany

Gives an evening and dawn effect to skies. A good "Red sky at night," effect.

Magenta

For colour effects.

Pink

For colour effects.

Neutral Density

Reduces exposure to selected areas without affecting colour balance.

Fog

An opaque "misty" effect, (as opposed to soft focus).

Low Contrast

A slight white opacity, lowers contrast by lightening dark areas.

Mist

Gives a mist/fog effect to selected areas of the image.

Net

Subtle soft focus effect. Hole gives clear centre if required.

Star

Precision manufacturing process gives a clear and subtle star effect.

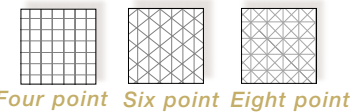
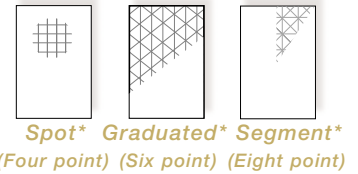
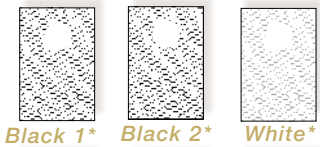
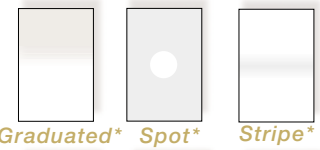
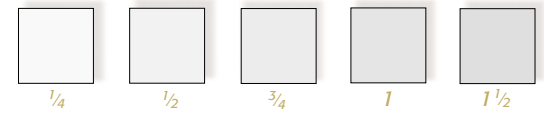

* available as part of a set
 † filter in the set is an extended graduated version

* available as part of a set

polarising filters

exposure increase 1½ Stop

These high quality glass filters manage the waveforms of light travelling to the camera from most reflective surfaces.

Glare and reflected light can be altered by rotation of the polarising filter. The effect can be seen through the lens of reflex cameras as the filter is rotated.

When used outside on sunny days, polarising filters have the effect of saturating colours and deepening blue skies. They can also be used in conjunction with other filters (although the polariser should always be placed in front of polyester filters to ensure it functions correctly).

Polarising filters are available in two types, linear and circular. This is not referring to the physical shape of the filter, but to the way the filter changes the light waves thereby achieving the polarising effect.

The type of polariser required (linear or circular) depends entirely on the type of camera the photographer is using. Modern reflex cameras with autofocus or complex metering systems, if used with a polariser, will only function correctly when a circular polariser is used. Manual focus cameras of all types can normally be used with either a linear or a circular type.

Both linear and circular polarisers are available from Lee Filters in both a rotating 105mm diameter version and a 100x100mm square version.

100mm square polarisers are to be used in the filter holder, the entire holder is then rotated to achieve the correct effect. Recommended for studio use or for when only the polariser and, possibly, standard filters are to be used.



105mm rotating polarisers are attached to the filter system via a special ring that is fitted to the front of the holder. This allows the polariser to be rotated independently of any grads used and is ideal for landscape photography where extra flexibility is required.

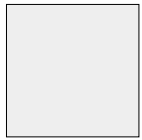

100 x 100mm square polariser
- circular and linear

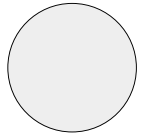

105mm rotating polariser
- circular and linear

unfiltered



filtered



glass enhancer

exposure increase 1 Stop

The glass enhancer offered by Lee Filters enhances mostly the red and orange elements in the spectrum by accentuating the other colours. Ideal for use in landscapes and some types of architectural photography, it causes many unusual effects with different types of light. Viewing the subject through the filter first, without mounting on the lens, helps to identify which parts of the picture will be affected.

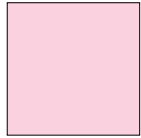

100 x 100mm enhancer

unfiltered



filtered



technical filters

Lee Technical Filters have been developed to provide practical solutions to specific problems met in both colour, and black and white photography. These filters are normally made from a high quality polyester base that is tough, impervious to water, and easy to clean.

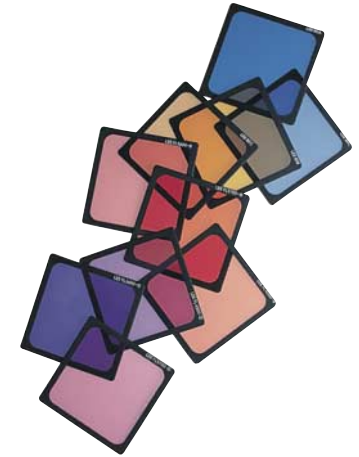

section contents

filter sets

forty nine *colour temperature set*
fine colour temperature set
warm up set
daylight fluorescent set
tungsten fluorescent set

fifty *neutral density set*
black and white set
magenta set
soft set

single filters

fifty one *colour temperature adjustment filters*

fifty two *neutral density filters*
combination filters

fifty three *fluorescent correction filters*
arc correction filters
ultra violet absorbing filters

fifty four *colour compensating filters*
tricolour filters
Infra-red filter

fifty five *filters for black and white photography*

technical sets

filter	conversion	approx exposure increase	mired shift
85B	5500K to 3200K	2/3 stop	+131
85C	5500K to 3800K	2/3 stop	+81
80C	3800K to 5500K	1 stop	-81
80A	3200K to 5500K	2 stops	-131

filter	conversion	approx exposure increase	mired shift
81D	3700K to 3200K	2/3 stop	+42
81A	3400K to 3200K	1/3 stop	+18
82A	3000K to 3200K	1/3 stop	-21
82C	2800K to 3200K	2/3 stop	-45

filter	conversion	approx exposure increase	mired shift
81	3300K to 3200K	1/3 stop	+9
81B	3500K to 3200K	1/3 stop	+27
81D	3700K to 3200K	2/3 stop	+42
85C	5500K to 3800K	2/3 stop	+81

filter	function	approx exposure increase	flash
FL3600-D	Balances warm-white tubes	1 2/3 stops	1/2 CTO + Plus Green
FL4300-D	Balances white tubes	1 stop	1/4 CTO + Plus Green
FL5700-D	Balances daylight/cool white tubes	2/3 stop	Plus Green

filter	function	approx exposure increase	flash
FL3600-B	Balances warm-white tubes	2/3 stop	1/2 CTO + Plus Green
FL4300-B	Balances white tubes	1 stop	1/4 CTO + Plus Green
FL5700-B	Balances daylight/cool white tubes	1 1/3 stops	Plus Green

colour temperature set

A set of four filters used to make major corrections to the colour temperature of light entering the camera. They create a balance between the colour temperature of the light source and the CT requirements of the film, so avoiding colour casts on the finished image.

fine colour temperature set

This set enables minor colour temperature corrections to be made, and is usually used for fine adjustment of colour temperature, creating a warm or cool feeling on the image.

warm up set

Four filters used to add warmth to portraits and landscapes. The degree of warmth increases across the range of the filters.

daylight fluorescent set

Camera filters for use when shooting under fluorescent lighting conditions with daylight film, together with a selection of lighting filters to be placed over the flashlight (if used) to balance the flashlight. All the light entering the camera, including that from the flashgun, must be given the same spectral output as the fluorescent, to allow perfect correction by the camera filter.

tungsten fluorescent set

Three camera filters for shooting under fluorescent lighting with tungsten film, together with a selection of lighting filters to place over a flashgun. The reasons for use are as described in the daylight fluorescent section.

technical sets

neutral density set

These three filters adjust exposure without affecting colour balance and can be used with all standard film types. Exposure can be increased by 1, 2 or 3 stops to suit individual requirements.

filter	colour	approx exposure increase
0.3 ND	neutral density	1 stop
0.6 ND	neutral density	2 stops
0.9 ND	neutral density	3 stops

black and white set

A quartet of filters which all absorb varying degrees of the blue and blue-green parts of the spectrum, creating different tones and contrasts of skies and foliage on black and white film. They can also be used to create special effects.

filter	colour	approx exposure increase
8	Yellow	1/3 stop
11	Yellow Green	1 1/3 stops
21	Orange	1 stop
23a	Light Red	2 stops

magenta set

Five CC Magenta filters which are used to absorb the green cast which can be found when photographing under fluorescent conditions. Using more than one filter at a time achieves greater absorption. These filters can additionally be used in conjunction with colour temperature filters to achieve an exact colour balance on film.

filter	colour	approx exposure increase
CC05M	Magenta	1/3 stop
CC10M	Magenta	1/3 stop
CC20M	Magenta	2/3 stop
CC25M	Magenta	2/3 stop
CC30M	Magenta	2/3 stop

soft set

The Soft Set consists of five filters, each offering a subtly different degree of diffusion for use in portraiture and landscape photography. The soft effect is virtually independent of aperture or focal length variations, and the degree of softening increases progressively through the range.

filter	type	exposure increase
Lee Soft 1	Light soft focus	not required
Lee Soft 2	Soft focus	" "
Lee Soft 3	Soft focus	" "
Lee Soft 4	Soft focus	" "
Lee Soft 5	Strong soft focus	" "

colour control

colour temperature adjustment filters

A range of filters which are used to convert the colour temperature of a light source to balance with the film type in use, or to create an intentional “warm” or “cool” effect.

description	filter	approx exposure increase	conversion	mired shift
Blue for major adjustment	80A	2	3200K to 5500K	-131
	80B	1 ² / ₃	3400K to 5500K	-112
	80C	1	3800K to 5500K	-81
	80D	2 ² / ₃	4200K to 5500K	-56
Pale Blue for fine adjustment	82C	2 ² / ₃	2800K to 3200K	-45
	82B	2 ² / ₃	2900K to 3200K	-32
	82A	1 ¹ / ₃	3000K to 3200K	-21
	82	1 ¹ / ₃	3100K to 3200K	-10
Pale Amber for fine adjustment	81	1 ¹ / ₃	3300K to 3200K	+9
	81A	1 ¹ / ₃	3400K to 3200K	+18
	81B	1 ¹ / ₃	3500K to 3200K	+27
	81C	1 ¹ / ₃	3600K to 3200K	+35
	81D	2 ² / ₃	3700K to 3200K	+42
	81EF	2 ² / ₃	3850K to 3200K	+53
Amber for major adjustment	85C	2 ² / ₃	5500K to 3800K	+81
	85	2 ² / ₃	5500K to 3400K	+112
	85B	2 ² / ₃	5500K to 3200K	+131

(mired shift can be negative as well as positive)

colour control

neutral density filters (ND)

These filters reduce light transmission uniformly over the visible region of the spectrum, in definitive steps. Although used mainly in colour photography for reducing light levels without colour change, they can also be used for black and white photography. They are particularly useful for compensating for too much light, in circumstances where changing the shutter speed, aperture or film type is not possible or desirable. For example, exposure time can be increased to achieve special effects when photographing running water and waterfalls etc., without adjusting the aperture. In addition, depth of field can be reduced by increasing the aperture by the stop value of the filter used. For example, if the aperture is required to be f4 yet correct exposure is at f8 and the speed cannot be changed, a 0.6ND filter will allow the setting of the f4 aperture.

neutral density	stop value	transmission %
0.1	1 ¹ / ₃	79.4
0.2	2 ² / ₃	63.1
0.3	1	50.0
0.4	1 ¹ / ₃	39.8
0.5	1 ² / ₃	31.6
0.6	2	25.0
0.7	2 ¹ / ₃	19.6
0.8	2 ² / ₃	15.9
0.9	3	12.5

combination filters (Comb)

A range of filters developed to provide selected colour temperature adjustments combined with neutral density in one filter.

CT/ND combination	approx exposure increase	conversion	mired shift
85BN3, 85BN6, 85BN9	1 ² / ₃ , 2 ² / ₃ , 3 ² / ₃	5500K to 3200K	+ 131
85N3, 85N6, 85N9	1 ² / ₃ , 2 ² / ₃ , 3 ² / ₃	5500K to 3400K	+ 112
81EFN3, 81EFN6, 81EFN9	1 ² / ₃ , 2 ² / ₃ , 3 ² / ₃	3850K to 3200K	+ 53

colour control

fluorescent correction filters (CC/CT)

This system offers filter solutions to many fluorescent correction problems. Both colour temperature conversion and green absorption functions are combined into one filter: the filter used will depend on the fluorescent light and film type.

film type	filter	approx exposure increase	light source
Tungsten (3200K)	FL 5700-B	1 1/3 stops	Cool White 5700K
	FL 4300-B	1 stop	White 4300K
	FL 3600-B	2/3 stop	Warm White 3600K
Daylight (5500K)	FL 5700-D	2/3 stop	Cool White 5700K
	FL 4300-D	1 stop	White 4300K
	FL 3600-D	1 2/3 stops	Warm White 3600K

arc correction filters (CC/CT)

These filters offer a single filter correction from mercury vapour or high pressure sodium lighting to daylight or tungsten film.

film type	filter	approx exposure increase	light source
Tungsten (3200K)	HPS-B	2 stops	High Pressure Sodium
	MV-B	2 stops	Mercury Vapour
Daylight (5500K)	HPS-D	3 stops	High Pressure Sodium
	MV-D	2 1/3 stops	Mercury Vapour

ultra violet absorbing filters (CC/CT)

A range of filters used to absorb varying amounts of ultra violet radiation which can cause haze or a bluish cast in distant landscapes, scenes over water, and aerial photography.

filter	description
1A	Maximum absorption of 0.076A (84%) at 535 nanometres
1B	Maximum absorption of 0.086A (82%) at 525 nanometres
2B	UV Absorption greater than 0.72A (19%) at 400 nanometres
2C	UV Absorption greater than 0.39A (40.5%) at 400 nanometres

colour control

colour compensating filters (CC/CT)

A range of filters recommended for use either in front of or behind the lens. They control the spectrum by reducing the transmission at specific wavelengths. They are primarily used to colour balance films, the required filter being determined as a result of tests, or as specified by the manufacturer. They can also be useful for correcting light sources for which no one conversion filter exists, or for adding a deliberate colour bias.

	025	05	10	15	20	25	30	40	50	
Cyan	Nil	1/3	1/3	1/3	1/3	1/3	2/3	2/3	2/3	Principally absorbs Red
Yellow	Nil	Nil	1/3	1/3	1/3	1/3	1/3	1/3	1/3	Principally absorbs Blue
Magenta	Nil	1/3	1/3	1/3	2/3	2/3	2/3	1	1	Principally absorbs Green
Red	Nil	1/3	1/3	1/3	2/3	2/3	2/3	1	1	Principally absorbs Blue & Green
Green	Nil	1/3	1/3	1/3	1/3	1/3	1/3	2/3	2/3	Principally absorbs Blue & Red
Blue	Nil	1/3	1/3	1/3	2/3	1	1 1/3	1 1/3	1 2/3	Principally absorbs Red & Green

The values shown are approximate exposure increases to compensate for the filters used.

tricolour filters (TR)

colour	filter	description	approx exposure increase
Tricolour Red	25	Separation filter. Maximum transmission above 610 nanometres. Also used for black and white contrast effects, haze penetration in aerial photography, and removing blue in infrared photography	2 1/2 to 3 stops
Tricolour Blue	47B	Separation filter. Maximum transmission at 440 nanometres	2 1/2 to 3 stops
Tricolour Green	58	Separation filter. Maximum transmission at 530 nanometres	2 1/2 to 3 stops

infrared (IR)

colour	filter	description
Infra-Red	87	This visually opaque filter is used in infrared photography to absorb unwanted visible light. Transmission begins above 730 nanometres.

colour control

filters for black and white (CC/CT) photography

The table below details the results achieved using the black and white filter range. All descriptions refer to the filter's effect when used with black and white film, (except where noted).

colour	filter	description	approx exposure increase
Light Yellow	3	Partially corrects for excess blue in aerial photography.	none
Yellow	8	Darkens sky, cloud and foliage to reproduce correct tones.	+ 1/3
Yellowish - Green	11	Used to alter the response of panchromatic emulsions, to be equivalent to the natural response of the eye to objects under tungsten illumination. Greens are reproduced slightly lighter in daylight.	+ 1 1/3
Deep Yellow	12	Minus blue filter. Can be used to cancel blue light when infrared-sensitive films are exposed. Also penetration of haze during aerial photography.	+ 1/3
Deep Yellow	15	Increases contrast between cloud and sky greater than No. 8, for over-correction effect. Also used for copying documents on yellowed paper.	+ 2/3
Yellow Orange	16	Gives even greater over-correction than No.15. Absorbs a small amount of green.	+ 2/3
Orange	21	Contrast filter. Absorbs blue and blue/green.	+ 1
Light Red	23A	Greater contrast effect than No. 21.	+ 2

The examples on the opposite page indicate how colours will be affected when using colour filters on black and white film.

unfiltered



unfiltered



light yellow 3



Darkens blue tones

yellow/green 11



Lightens greens / darkens reds

orange 21



Lightens reds / darkens some blue and blue/green

light red 23A



Dramatically lightens reds and darkens blue and green

accessories



gel snap

Probably the simplest polyester filter holder available, the Gelsnap is designed to work with both framed or unframed filters. The gelsnap fits to the front of virtually every camera setup and can also be used behind the lens on large format cameras.

Simply insert any 100mm polyester or gelatin filter, snap it shut and then attach it to the lens using the band provided.

system accessories

Lee Filters offers a wide range of accessories to support its holder system. These include:

Tandem adaptors.

Mounts which enable 84mm filters, both square and oblong, to be used with the Lee Filter system.

Mounts for polyester filters (75 x 75mm and 100 x 100mm).

Holder guides for using extra filters.

Screws of varying lengths.

A filter cleaning solution for use on resin and glass filters.

A high quality cleaning cloth which can be used either dry or with the cleaning solution.



multi-filter pouch

The multi-filter pouch holds up to ten filters and is an ideal way to store and transport resin filters.



leather filter pouch

This pouch will take up to six filters and is designed for quick and easy filter selection when out on location.

Whether sat in a gadget bag, or clipped onto a belt, the photographer's favourite filters will be kept safe and protected until he or she needs them.

This hardwearing pouch is finished in a high quality leather.



darkroom

products

colourweb

Finding the most appropriate enlarger filtration when producing colour prints can be a time-consuming and costly process. It often takes a number of test prints, wasting both time and valuable photographic paper, before the desired result is reached. The Colourweb is an easy-to-use processing tool which enables the photographer to select the correct filter combination for balanced colour prints from colour negatives, with the minimum of fuss. Using Colourweb could not be easier. Simply print a test using an average starting filtration, assess the print and decide on the window with the most acceptable colour balance, note the filtration change needed and adjust the filtration and exposure. You are now ready to make a print.

colour printing filters

These filters are for use between the light source and the negative or transparency. They are available in the same colour and density ranges as the colour compensating filters. Please note: only colour correction quality filters should be used in the image forming beam.

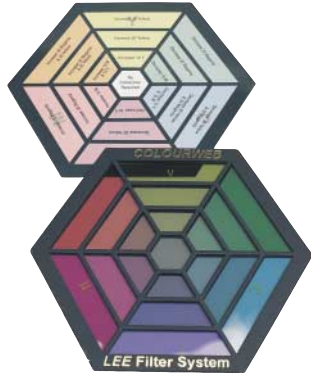

viewing kit

The Viewing Kit can be used to evaluate the colour balance of a transparency or print. Each kit contains six cards - one for each compensating filter colour: cyan, yellow, magenta, red, green and blue. For each colour there are filter pieces of the most useful densities, arranged in sequence around a central clear filter. The slide or transparency should be viewed through the cards enabling the correct filtration to be identified.

print easy

The Print Easy viewing kit makes colour printing from either negative or transparencies simplicity itself. It has been produced as a result of demand for an easy to use, inexpensive colour printing aid.

The Print Easy kit contains six colour cards – yellow, cyan, magenta, red, green and blue, each of which has three windows holding filters of differing strength. All you have to do is to make one unfiltered test print, then view it through the windows on the colour cards until you find the filter, or combination of filters, that gives you an acceptable result.



lighting filters



Pro-pack

The Lee Filters Pro-Pack kit contains 23 specially selected different sheets of filter material, and represents a versatile package for the studio.

15 colour effect-filters used for lighting backgrounds and creating special effects. Colours are yellow, straw, deep amber, orange, primary red, dark pink, magenta, peacock blue, dark blue, fern green, dark green, mauve, medium blue, flame red and deep lavender.

The four colour temperature correction grades (Full and Half Colour Temperature Blue, and Full and Half Colour Temperature Orange) are used to balance colour temperature when working in a combination of daylight and tungsten lighting conditions.

Two Neutral Density (0.3ND and 0.6ND) grades can be used to reduce the power of a flash head or studio lamp, to balance the intensities of lights or flash.

Completing the package are two white diffusers, for use on their own or with other filters to eliminate shadows and soften the overall lighting effect.

reflector pack

Containing reflectors in mirror gold, mirror silver, soft gold and soft silver, the sheets are all manufactured from the same high quality, lightweight and flexible material that you would expect from Lee Filters. They can be used as they are or mounted on polystyrene or board for added rigidity. They are ideal for use in both the studio or out on location.

Pro-pack and reflector packs are available in 610mm x 530mm sheets.

polariser

This is available in a 480mm by 480mm sheet and is intended for use with light sources. Care must be taken not to position the filter too close to a hot lamp.



colour magic



The Lee Filters **colourMAGIC** series is a set of eight individual packs each containing a selection of 12 filters (250mm x 300mm), related to a particular aspect of lighting and studio work. **colourMAGIC** offers an opportunity to get to know the performance of the various filters on offer in a cost-effective way.



original pack

a specific selection of colours that can be used together to create a range of additional colours

contents

yellow, medium blue green, light blue, fern green, mauve, bright pink, heavy frost, no colour blue, chrome orange, dark lavender, flesh pink, brushed silk



studio plus pack

a range of technical filters for fine control of light sources

contents

2x half C.T.B, 2x quarter C.T.B, 2x eighth C.T.B, 2x half C.T.O, 2x quarter C.T.O, 2x eighth C.T.O



light tint pack

paler shades to give more subtle effects and to filter white light from the lamp

contents

lavender tint, pale yellow, pale amber gold, light pink, mist blue, pale blue, straw, pale rose, bastard amber, lilac tint, white flame green, hollywood frost



complementary pack

a starter pack for exploring the basics of colour addition and subtraction

contents

flame red, dark green, dark blue, loving amber, dark steel blue, pale green, yellow, peacock blue, bright pink, pale yellow, steel blue, light pink



studio pack

a range of technical filters for basic light source control

contents

2x full C.T.B, 2x three quarters C.T.B, 2x full C.T.O, 2x three quarters C.T.O, 0.15 neutral density, 0.3 neutral density, 0.6 neutral density, 0.9 neutral density



saturates pack

a selection of strong and vibrant colours for more intense colour combinations

contents

medium red, yellow, orange, medium blue green, deep blue, mauve, heavy frost, deep golden amber, primary green, congo blue, light red, special rose pink



tint pack

lighting filters which complement the original colour magic pack to create alternative shades

contents

rose pink, rose purple, lime green, spring yellow, english rose, marine blue, pink, flame red, dark steel blue, brushed silk, half white diffusion, violet



arc correction pack

a selection of technical filters for colour correction

contents

2x half C.T.O, 2x quarter C.T.O, Lee fluorescent green, Lee fluorescent 5700K, Lee fluorescent 4300K, Lee fluorescent 3600K, 2x full plus green, 2x half plus green

index

pages

	<i>page number</i>		<i>page number</i>
80A	49,51	Colour temperature adjustment filters	51
80B	51	Colour temperature set	49
80C	49,51	colourMagic series	63
80D	51	colourMagic series - Arc correction pack	63
81	51	colourMagic series - Complementary pack	63
81A	49,51	colourMagic series - Light tint pack	63
81B	49,51	colourMagic series - Original pack	63
81C	51	colourMagic series - Saturates pack	63
81D	49,51	colourMagic series - Studio pack	63
81EF	51	colourMagic series - Studio plus pack	63
81EFN3, 81EFN6, 81EFN9	52	colourMagic series - Tint pack	63
82	51	Colourweb	59
82A	49,51	Combination filters (comb)	52
82B	51	Coral 1, 3, 5, 7, 8, 9, 10, 11, 12, 13, 14,	42
82C	49,51	Coral 2	31, 42
85	51	Coral 4	31, 42
85B	49,51	Coral 6	24, 31, 42
85C	49,51	Coral set	31
85BN3, 85BN6, 85BN9	52	Coral Stripe	23, 42
85N3, 85N6, 85N9	52	Cyan	29, 43
		Cyan 1	32, 43
Accessories	57	Cyan CC filter	54
Arc correction filters (CC/CT)	53	Cyan stripe	34
Autumn tint set	24		
		Darkroom products	59
Black and white set	50	Daylight fluorescent set	49
Black and white filters (CC/CT)	55, 56	Double slotted filter hood	15
Blue CC filter	54		
Blue Pop	42	Effects filters	21
Blue Stripe	42		
		Filter holder	8
Chocolate 1	42	Filter versatility	9
Chocolate 2	24, 42	Fine colour temperature set	49
Colour compensating filters (CC/CT)	54	FL 3600-B	49,53
Colour control filters	51	FL 3600-D	49,53
Colour grad set	29	FL 4300-B	49,53
Colour printing filters	59		

index

pages

	page number		page number
FL 4300-D	49,53	Mist stripe	35, 44
FL 5700-B	49,53	Multi-filter pouch	58
FL 5700-D	49,53	MV-B	53
Fluorescent correction filters (CC/CT)	53	MV-D	53
Fog 1, 2, 3, 4, 5	44		
Foundation kit	11		
		Net black 1	39, 40, 44
Gel snap	57	Net black 2	39, 44
Glass enhancer	36, 47	Net set	39
Glass filters	18	Net white	39, 40, 44
Glass Soft Focus filter	37	Neutral density 0.3 (resin)	19, 22, 43
Green 1	32, 42	Neutral density 0.45 (resin)	19, 43
Green CC filter	54	Neutral density 0.6 (resin)	19, 20, 22, 43
Green pop	42	Neutral density 0.75 (resin)	19, 20, 28, 43
		Neutral density 0.9 (resin)	19, 22, 31, 33, 43
HPS-B	53	Neutral density filters (polyester)	52
HPS-D	53	Neutral density graduated	19
		Neutral density set (polyester)	50
		Neutral density set (resin)	22
Infrared (IR)	54	Neutral density single filters (polyester)	52
		Neutral density single filters (resin)	43
Landscape set	28		
Leather filter pouch	58	Pale coral stripe	26, 41
Lens adaptors	6	Pale tint set	32
Lens hoods	14	Pink 1	32, 43
Lighting filters	61	Pink stripe	34, 43
Low contrast 1/4, 1/2, 3/4, 1, 1 1/2	44	Polariser	62
		Polarising filters	45
Magenta	29, 43	Polyester filters	18
Magenta CC filter	54	Pop blue	33, 34
Magenta set	50	Pop green	33
Mahogany 1	27, 43	Pop red	33
Mahogany 2	43	Pop set	33
Mahogany 3	26, 43	Print easy viewing kit	60
Mist graduated	35, 44	Professional kit	11
Mist set	35	Pro-pack	61
Mist clear spot	35, 44	Push on filter holder	12

index

pages

	page number		page number
Real blue 1	19, 43	Sunset 1, 3	41
Real blue 2	28, 43	Sunset 2	23, 41
Real blue 3	43	Sunset orange	25, 41
Red CC filter	54	Sunset red	25, 41
Red pop	41	Sunset set	25
Reflector pack	62	Sunset yellow	25, 41
Resin filters	17	System accessories	57
Selective star set	36	Technical filters	48
Sepia 1, 3	42	Technical filter set	49
Sepia 2	28, 42	Tobacco 1, 3	42
Service	18	Tobacco 2	24, 42
Single resin filters	41	Tricolour filters (TR)	54
Sky blue 1, 2	30, 43	Tungsten fluorescent set	49
Sky blue 3	23, 30, 43	Twilight	26, 43
Sky blue 4, 5	43	Twilight set	26
Sky blue set	30		
Sky set	23	Ultra violet absorbing filters (CC/CT)	53
Slotted filter hood	15	Universal hood	16
Slotted wide-angle lens hood	16	Upgrade kit	11
Soft focus	37		
Soft set	38, 50	Viewing kit	60
Soft 1, 2, 3, 4, 5	38, 38		
Specialist filter holders	12	Warm up set	49
Standard hood	15	Wide-angle lens hood	16
Star eight point	44		
Star four point	44	Yellow	29, 41
Star graduated	36, 44	Yellow CC filter	54
Star segment	36, 44	Yellow stripe	34, 41
Star six point	44		
Star spot	36, 44		
Straw 1	41		
Straw 2	27, 41		
Straw 3	28, 41		
Straw Stripe	27, 41		
Stripe set	34		
Sunrise set	27		

Whilst every effort has been made, we cannot guarantee the accuracy of the colours in this brochure due to the limitations of the printing process